

## Flow Switch

© Copyright 2009 Caleffi

**626 Series**



### Function

The Caleffi Series 626 water flow switch detects the presence or absence of flow in piping of heating, air conditioning, cooling and water treatment systems as well as in pumping and process systems. In heating systems, the flow switch is normally used to shut off the burner of the boiler whenever there is no circulation of the carrier fluid in the boiler circuit. A lack of circulation can damage critical components and impair the operation of temperature sensitive safety and protection devices.

### General Characteristics

A stainless steel bellows separates the electrical and hydronic sections, preventing the possibility of contact of the fluid with the electrical components. Stainless steel is used in the construction of many key parts, including the bellows which protects the switch from corrosion. With a protection classification of NEMA type 5 (IP54), the switch can be used in particularly humid and dusty environments. The cover is made of a special non-combustible plastic material. The normally open and normally closed contacts on the switch enable any electrical device to be switched on or off as required at the operating flow rate. The operating point can be easily adjusted with the calibration screw.

### Technical Characteristics

Connection size:	1" NPT male
Maximum operating pressure:	150 psig (10 bar)
Maximum temperature of the fluid:	250° F (120°C)
Minimum temperature of the fluid:	-20° F (-30°C)
Maximum ambient temperature:	130° F (55°C)
Suitable for pipes:	1" to 8" (25 to 200 mm)

### Electrical Data

Max Voltage:	250 VAC
Current:	15 A
Electrical connection:	1/2" NPT threaded
Protection class:	NEMA type 5 (IP54)
Certification Mark:	



### SAFETY INSTRUCTION

This safety alert symbol will be used in this manual to draw attention to safety related instructions. When used, the safety alert symbol means **ATTENTION! BECOME ALERT! YOUR SAFETY IS INVOLVED! FAILURE TO FOLLOW THESE INSTRUCTIONS MAY RESULT IN A SAFETY HAZARD.**



**CAUTION:** All work must be performed by qualified personnel trained in the proper application, installation, and maintenance of systems in accordance with all applicable codes and ordinances.



**CAUTION:** Over-tightening and breakage can occur with the use of PTFE pipe joint compounds. PTFE provides lubricity so that care must be exercised not to over-tighten joints. Failure to follow these instructions could result in property damage and /or personal injury.

## Installations

To install the flow switch correctly follow these instructions:

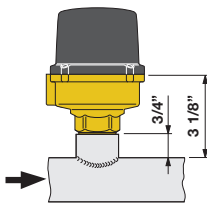

- Select the blade marked with the diameter of the pipe in which the switch is to be installed;
- Remove any extra pre-fitted blades for larger diameter pipes by unscrewing the 2 blade attaching screws;
- With pipe diameters of 3" (DN 80) or above, all the pre-fitted blades must be attached in ascending order with the long blade being cut to the size corresponding to the desired pipe diameter;
- Fit the flow switch to the pipe, carefully observing the direction of flow indicated by the arrows stamped on the cover and on the switch mounting plate. When fitted, the distance between the upper surface of the pipe and upper surface of the switch mounting plate should be 3 1/8" (80 mm);

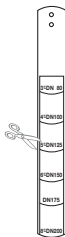
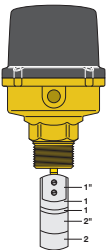

- The tee connection in the pipe can be formed by the direct welding of a threaded socket;
- This also applies to a 1" (DN 25) diameter pipe, as the blades are designed to be contained in these smaller dimensions.
- It is however advisable to check that the weld is free from burrs on the inside so that the blade can move freely in the tee connection;
- Whenever possible the flow switch should be installed in the vertical position to avoid deposits of impurities which may cause it to function incorrectly.



**WARNING:** Electrical shock hazard. Disconnect **ALL** power sources when installing or servicing this equipment to prevent electrical shock or equipment damage. Failure to follow these instructions could result in property damage and/or personal injury.

## Electrical Connections

Unscrew the four cover screws and lift off the outer cover.



Make sure the wires do not obstruct the function of the switch mechanism.

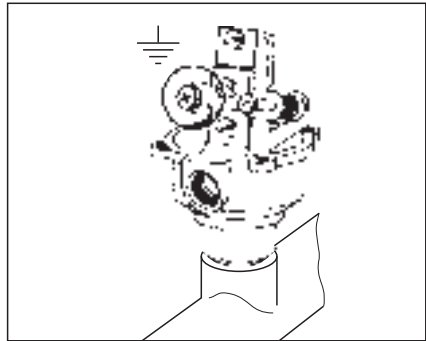

## Diagrams showing the internal connections of the micro-switch with:

Flow switch is used to activate a device when flow starts.

When flow starts and the increasing operating flow is reached or exceeded, the common (black wire) and normally open (red wire) contacts are closed, while the common (black wire) and the normally closed (blue wire) contacts are open.

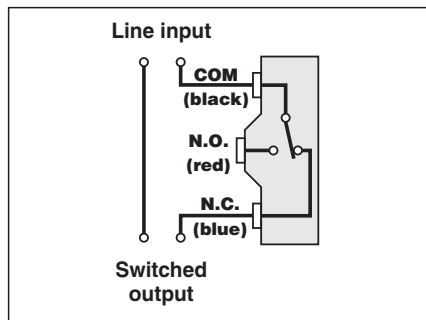

Flow switch used to activate a device when flow stops.

When the decreasing operating flow is reached or stops the common (black wire) and the normally open (red wire) contacts open, while the common (black wire) and the normally closed (blue wire) contacts close.

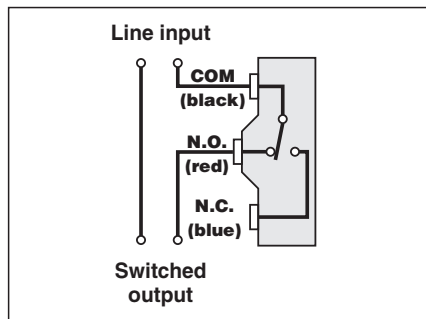

## Electrical Rating

	125 V <sub>AC</sub>		250 V <sub>AC</sub>	
	N.C.	N.O.	N.C.	N.O.
Resistive Load	15 A	15 A	15 A	15 A
Inductive Load	15 A	15 A	15 A	15 A
Motor Load	5 A	2.5 A	3 A	1.5 A
Horsepower	1/8 HP	1/8 HP	1/4 HP	1/4 HP

## Calibration

The minimum and maximum operating flow rates are given in the table below. Adjustments should be carried out as follows: turn the calibration screw (A) in a clockwise direction for the contacts to close at higher flow rate values or in a counterclockwise direction for lower flow rate values. When the adjustment has been made lock the screw (A) with the locking ring nut (B). **Avoid all contact with the presetting screw (C).** An incorrect setting would seriously impair the operation of the switch.

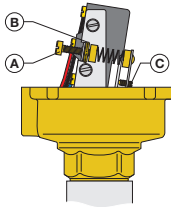

## Operating flow rates: gpm (lpm)

Diameter of pipe	1"	1 1/4"	1 1/2"	2"	2 1/2"	3"	4"	5"	6"	8"
<b>Minimum calibration</b> Operating flow rate with <b>increasing flow</b>	5.7 (21.7)	7.5 (28.4)	11.4 (43.4)	13.2 (50.1)	22.0 (83.5)	29.9 (113)	44.0 (167)	61.1 (232)	72.6 (275)	162 (618)
<b>Minimum calibration</b> Operating flow rate with <b>decreasing flow</b>	4.0 (15.0)	5.5 (20.9)	8.4 (31.7)	9.7 (36.7)	16.3 (61.8)	22.9 (86.8)	37.4 (142)	51.5 (197)	63.8 (242)	145 (551)
<b>Maximum calibration</b> Operating flow rate with <b>increasing flow</b>	12.3 (46.8)	16.7 (63.5)	26.0 (98.5)	29.5 (112)	51.5 (195)	69.5 (264)	94.6 (359)	136 (518)	189 (718)	334 (1269)
<b>Maximum calibration</b> Operating flow rate with <b>decreasing flow</b>	11.9 (45.1)	16.3 (61.8)	25.5 (96.9)	29.0 (110)	50.6 (192)	68.6 (260)	92.4 (351)	127 (484)	158 (601)	308 (1169)



Caleffi North America, Inc.  
3883 W. Milwaukee Road  
Milwaukee, WI 53208  
T: 414.238.2360 F: 414.238.2366