



Advance Metalpres Inc.
 2400 Viscount Way
 Richmond, BC, Canada
 V6V 1N1
 Tel: (604) 279-8266
 Fax: (604) 279-8265

Tank Model	Tank Capacity US Gal.	Shipping Weight LBS.	Tank Height Z in.	Diameter W in.	Recirc. Inlet - M in.	Recirc. Outlet - N in.
J 40 ST/SE	40	105	42 ½	21 ¼	14 ¼	8 ¼
J 60 ST/SE	60	137	62 ½	21 ¼	14 ¼	8 ¼
J 80 ST/SE	80	240	66 ½	23	15 ¾	9 ½
J 120 ST/SE	119	300	70 ½	27	15 ¾	9 ½

J-STSE

Insulated Storage Tank

Maximum Operating Pressure 150 psi

Connections:

Model	40 & 60	80	120
A Hot Water Outlet	3/4" NPT nipple	1" NPT nipple	2" NPT nipple
B Cold Water Inlet	3/4" NPT nipple	1" NPT coupling	1 1/4" nipple
C Redirc. In	1 ¼" NPT coupling	2" NPT coupling	2" NPT coupling
D Redirc. Out	1 ¼" NPT coupling	2" NPT coupling	2" NPT coupling
E Aquastat	1/2" NPT coupling	1/2" NPT coupling	1/2" NPT coupling
F Temp. Gauge	Surface mount		
G Relief Connect	3/4" NPT coupling	3/4" NPT coupling	3/4" NPT coupling
H Drain	3/4" NPT coupling	3/4" NPT coupling	N/A

The method of using **Indirect Fired Hot Water Tanks** has become increasingly popular world wide. The combination of **efficiency** and **high recovery rate** provided by the **J Series** Indirect Hot Water Tank and Storage Tanks rewards the user with both **energy savings** and comfort of uninterrupted hot water usage. Storage tanks are ideal for commercial, industrial and residential applications that require a large demand for Domestic Hot Water. Ideally used in conjunction with our tankless coil **Double Wall heat exchanger**

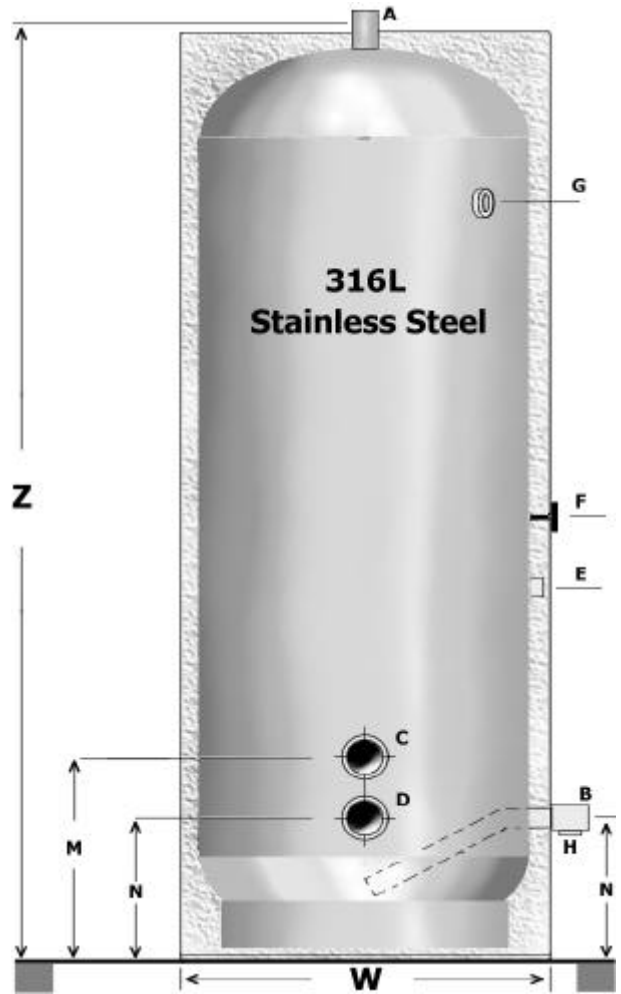

** Passivated Treatment for Maximum Corrosion Resistance. **

The J Series Tank Features:

- Complete package with Aquastat, Temperature Gauge, Temp-Pressure Relief Valve and Drain Valve **drain not supplied with J120
- 100% High Quality 316L Stainless Steel Construction
- High Capacity storage for commercial and industrial applications
- Designed for quick and simple installation
- Powder coated steel jacket for high quality finish and durability
- Non toxic fibreglass insulation

LIMITED WARRANTY
15 YEARS RESIDENTIAL
5 YEAR COMMERCIAL